



## WL20e

### Wheel Loader

Electric, practical, emission-free

The WL20e is the first exclusively electric-powered wheel loader by Wacker Neuson. Its performance characteristics correspond to those of a conventional diesel-powered machine. The installed 48-volt lithium-ion battery is optionally available in three power levels, so that running and charging times can be optimally matched to the work requirements. The WL20e works fully emissions-free on site and with significantly lower noise pollution. For the end user, this means greater flexibility in application, environmental protection and significant savings on operating costs.

## Highlights

- Innovative technology, proven in the field
- Powerful lithium-ion battery
- Easy charging options
- Comfortable cab
- EPS folding overhead guard (Easy Protection System)

## Technical Data

### ■ Standard battery

Battery technology	Lithium-ion
Battery voltage class	48 V
Battery capacity	14.1 kWh
Battery weight	132 kg
On-board charging capacity (max.)	3 kW
Loading time (0-100%)	4 - 6* h
Loading time (20-80%)	2,9* h
Running time up to	3,27** h

### ■ Battery Option 1

Battery technology	Lithium-ion
Battery voltage class	48 V
Battery capacity	18.7 kWh
Battery weight	148 kg
On-board charging capacity (max.)	6 kW
Loading time (0-100%)	3 - 8* h
Loading time (20-80%)	1,9* h
Running time up to	5,07** h

### ■ Battery Option 2

Battery technology	Lithium-ion
--------------------	-------------

Battery voltage class	48 V
Battery capacity	23.4 kWh
Battery weight	165 kg
On-board charging capacity (max.)	6 kW
Loading time (0-100%)	4 - 10* h
Loading time (20-80%)	2,4* h
Running time up to	7,30** h

### ■ Electric motor

Motor traction drive (EN60034-1)	6,5 kW
Motor work hydraulics (EN60034-1)	8.5 kW

### ■ Electrical system

Operating voltage	12 V
-------------------	------

### ■ Weights

Bucket capacity (standard bucket)	0.19 m <sup>3</sup>
Operating weight	2,170 - 2,350 kg
Tipping load with bucket – machine straight, loading frame horizontal	1,550 - 1,620 kg
Tipping load with bucket – machine pivoted, loading frame horizontal	1,210 - 1,320 kg
Tipping load with pallet fork – machine straight, loading frame horizontal	1,110 - 1,160 kg
Tipping load with pallet fork – machine pivoted, loading frame horizontal	860 - 940 kg

### ■ Driver's cab

Driver's cab	FSD (EPS, cabin)
--------------	------------------

### ■ Filling levels

Tank capacity for hydraulic oil	20 l
---------------------------------	------

### ■ Drive system

Type of drive	Electrical
drive unit	universal joint shaft
Speed levels	1
Axle	T80
Travel speed Standard	0-15 km/h
Operating brake	Drum brake acting on all four wheels
Parking brake	Electrical

### ■ Hydraulic system

Work hydraulics discharge volume (max.)	32 l/min
Work hydraulics working pressure (max.)	225 bar

### ■ Kinematics

Kinematics type	P
Lifting cylinder	2
Tipping cylinder	1
Quick change system	hydraulic

### ■ Steering

Steering type	hydraulically activated articulated pendulum steering
Steering cylinder	1
Oscillating angle	± 12 degree

### ■ Noise characteristic values

Average sound power level LwA (operator's canopy)	85.1 dB(A)
Guaranteed sound power level LwA (operator's canopy)	87 dB(A)
Specified sound pressure level LpA (operator's canopy)	76 dB(A)
Average sound power level LwA (cabin)	85.1 dB(A)
Guaranteed sound power level LwA (cabin)	87 dB(A)
Specified sound pressure level LpA (cabin)	75 dB(A)

### ■ Other information

FSD = overhead guard  
 EPS = Easy Protection System (fold-down overhead guard)  
 Tipping load calculation pursuant to ISO 14397

\*The charging time is dependent on different charging options. Onboard charger 3 kW (standard) with auxiliary onboard charger, total 6 kW (option). The following charging plugs are available: 230 V / 10 A Schuko, 230 V / 16 A CEE (blue, 3-pole), 400 V / 16 A CEE (red, three-phase current, 5-pole), 400 V / 16 A (type 2 Wallbox plug, IEC 62196) and other adapter plugs.

\*\*The battery charging times are dependent on the respective application conditions, the task being performed and the driving style. This can result in a longer running time. However, in extreme cases, it is also possible that you may fall short of the specified running times. The specified running times refer to uninterrupted operation and working with the machine.

## Dimensions

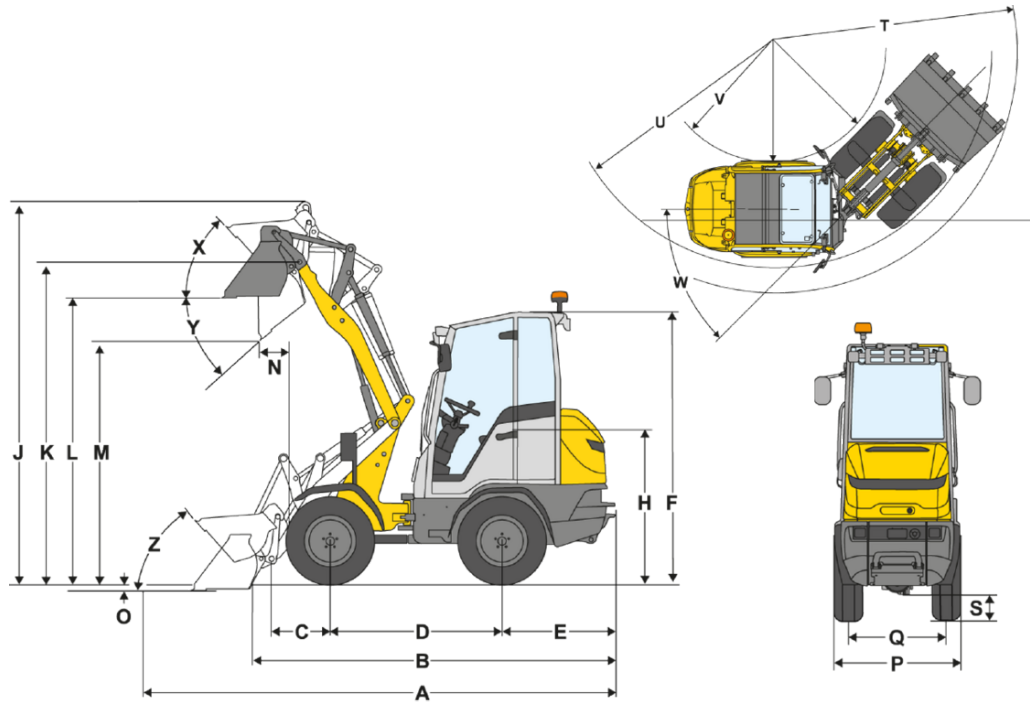

A	Total length	3,697 mm
B	Total length without bucket	3,061 mm
C	Bucket pivot point (to center of axle)	509 mm
D	Wheel base	1,468 mm
E	Rear overhang	971 mm
F	Height with operator's canopy (fixed)	2,259 mm
	Height with fold-down operator's canopy (EPS)	2,336 mm
F	Height with fold-down operator's canopy (EPS), folded down	1,939 mm
	Height with cab	2,301 mm
H	Seat height	1,292 mm
J	Total working height	3,248 mm
K	Bucket pivot point (max. lift height)	2,710 mm
L	Load-over height	2,436 mm
M	Dumping height	2,017 mm
N	Reach (at M)	296 mm
O	Digging depth	83 mm
P	Total width	1,052 mm
Q	Track width	804 mm
S	Ground clearance	219 mm
T	Maximum radius	2,645 mm
U	Radius on the outer edge	2,379 mm
V	Inner radius	1,205 mm
W	Articulation angle	45 °
X	Rollback angle at max. lift height	50 °
Y	Dumping angle	40 °
Z	Rollback angle on ground	49 °